



A Division of Abston Machine Shop inc.

Directions For:

JPL4400, JPL4500, JPL4550, JPL4600, JPL4800, JPL5500, JPL7500SS

JACK PLATES

The JPL4400, JPL4500, JPL4550, JPL4600, JPL4800, JPL5500, and JPL7500SS Single Adjusting Jack Plate should be mounted using 1/2" diameter stainless steel mounting bolts and stainless steel lockout. (A bolt kit is available from Vance Mfg. online at vancemfg.com) The short side of the assembly faces against the boat transom with the long side against the motor.

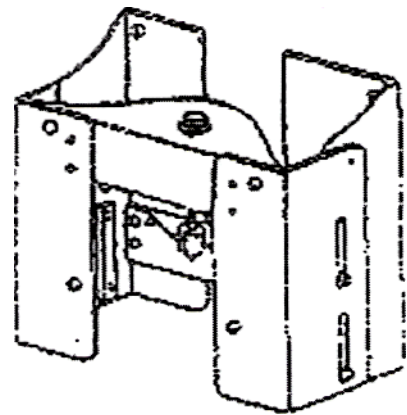

The adjusting will be at the Top of the assembly when installed. To adjust the Jack Plate loosen 6 side bolts and turn the adjusting stud in the center clockwise to raise motor. To lower motor turn adjusting stud counter clockwise.

Always tighten side bolts after adjusting height!

ALL BOLTS SHOULD BE TIGHTENED PERIODICALLY!

For more information visit www.vancemfg.com

Email: support@vancemfg.com